

## Installation Instructions for the High Voltage and ESD Protection Bipolar Hall-Effect Digital Position Sensor ICs: SS41K6

# 32340615

Issue B

### GENERAL INFORMATION

#### CAUTION ELECTROSTATIC DISCHARGE DAMAGE

Ensure proper ESD precautions are followed when handling this product.

**Failure to comply with these instructions may result in product damage.**



Wave solder at 250°C to 260°C [482°F to 500°F] for a maximum of three seconds. Burrs are allowed only if full lead length will pass through a 0,68 mm [0.027 in] dia. hole.

### CLEANING

#### CAUTION IMPROPER CLEANING

Do not use pressure wash. High-pressure stream could force contaminants into the package.

**Failure to comply with these instructions may result in product damage.**

Use agitated rinse to clean the sensor.

### SOLDERING AND ASSEMBLY

#### CAUTION IMPROPER SOLDERING

- Ensure leads are adequately supported during any forming/shearing operation so that they are not stressed inside the plastic case.
- Limit exposure to high temperatures.

**Failure to comply with these instructions may result in product damage**

**Table 1. Performance Specifications (At  $V_S = 4.5\text{ V to }60\text{ V}$ ,  $T_A = -40^\circ\text{C to }150^\circ\text{C}$  [-40°F to 302°F],  $I_O = 15\text{ mA}$ , except where otherwise specified.)**

Characteristic	Symbol	Condition	Min.	Typ.	Max.	Unit
Supply voltage	$V_S$	— -40°C to 125°C [-40°F to 257°F] 150°C [302°F]	4.5 4.5 4.5	— — —	60.0 60.0 24.0	V
Supply current	$I_S$	—	—	3.6	10.0	mA
Output voltage (ON)	$V_{SAT}$	$I_O = 15\text{ mA}$	—	0.215	0.600	V
Output leakage current	$I_{OH}$	—	—	—	10.0	μA
Output current limit <sup>1</sup>	$I_{O(SCP)}$	short circuit protection <sup>1</sup>	40	—	—	mA
Output switching time: rise time	$t_r$	$T_A = 25^\circ\text{C}$ [77°F]	—	—	1.5	μs
fall time	$t_f$	$T_A = 25^\circ\text{C}$ [77°F]	—	—	1.5	μs
ESD (Human Body Model)	$V_{ESD}$	per JEDEC JS-001-2014	-16	—	16	kV
Operating temperature	$T_A$	—	-40 [-40]	—	150 [302]	°C [°F]
Junction temperature	$T_J$	—	-40 [-40]	—	165 [329]	°C [°F]
Storage temperature	$T_S$	—	-40 [-40]	—	150 [302]	°C [°F]
Thermal resistance	$R_{\theta JA}$	—	—	—	233	°C/W
Soldering time and temperature	—	3 s max.	250 [482]	—	260 [500]	°C [°F]

<sup>1</sup> Output short circuit protection is enabled when the output load current exceeds the rated load current.

### NOTICE

These Hall-effect sensor ICs may have an initial output in either the ON or OFF state if powered up with an applied magnetic field in the differential zone (applied magnetic field  $>B_{RP}$  and  $<B_{OP}$ ). Honeywell recommends allowing 10 μs after the supply voltage has reached 4.5 V for the output voltage to stabilize.

### NOTICE

The magnetic field strength (Gauss) required to cause the switch to change state (operate and release) will be as specified in the magnetic characteristics (see Table 2). To test the switch against the specified limits, the switch must be placed in a uniform magnetic field.

# SS41K6

## Bipolar Hall-Effect Digital Position Sensor ICs

Issue B  
32340615

**Table 2. Magnetic Characteristics (At  $V_S = 4.5\text{ V to }60\text{ V}$ ,  $T_A = -40^\circ\text{C to }150^\circ\text{C}$  [-40°F to 302°F], except where otherwise specified.)**

Characteristic	Symbol	Condition	Min.	Typ.	Max.	Unit
Operate	$B_{OP}$	$T_A = 25^\circ\text{C}$ [75°F]	—	25 25	115 65	Gauss
Release	$B_{RP}$	$T_A = 25^\circ\text{C}$ [75°F]	-115 -65	-25 -25	—	Gauss
Differential	$B_{DIF}$	—	30	—	—	Gauss

**Table 3. Absolute Maximum Specifications**

Characteristic	Symbol	Condition	Min.	Typ.	Max.	Unit
Supply voltage	$V_S$	—	-0.5	—	60.0	V
Output voltage	$V_O$	—	-0.5	—	60.0	V
Output current	$I_O$	—	—	—	N/A <sup>1</sup>	mA
Magnetic flux	B	—	—	—	no limit	Gauss

<sup>1</sup> Output short circuit protection is enabled when the output load current exceeds the rated load current shown in Table 1.

### NOTICE

Absolute maximum ratings are the extreme limits the device will momentarily withstand without damage to the device. Electrical and mechanical characteristics are not guaranteed if the rated voltage and/or currents are exceeded, nor will the device necessarily operate at absolute maximum ratings.

**Figure 1. Magnetic Characteristics vs Temperature**

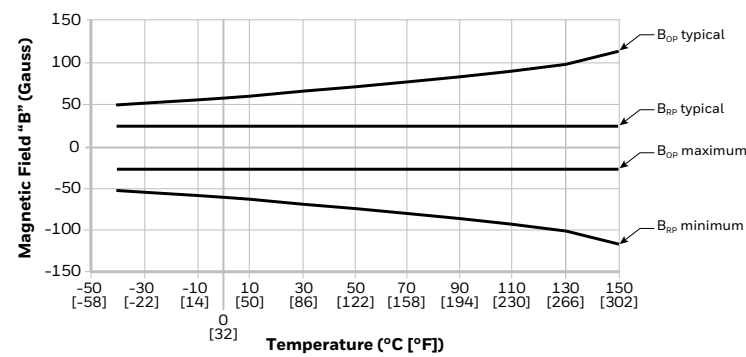

**Figure 2. Power Derating Curve**

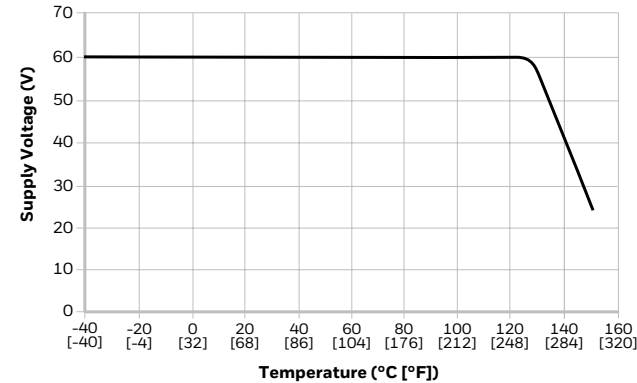

**Figure 3. Transfer Characteristics**

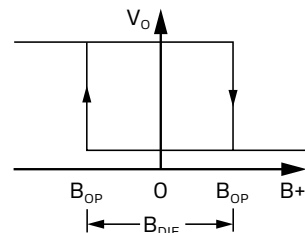

**Figure 4. Transfer Characteristics Definition**

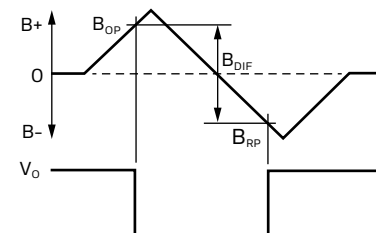

**Figure 5. Current Sinking Output Block Diagram**

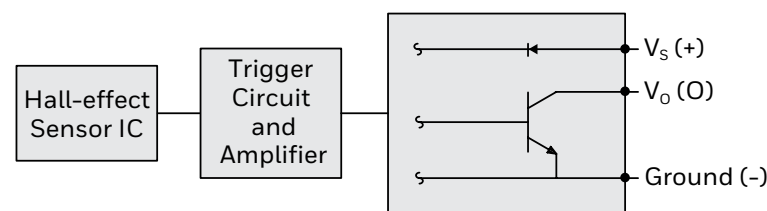

**Figure 6. Basic Application Circuit**

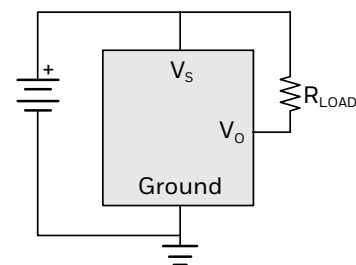

# SS41K6

## Bipolar Hall-Effect Digital Position Sensor ICs

Issue B  
32340615

**Figure 7. Wiring Diagrams**

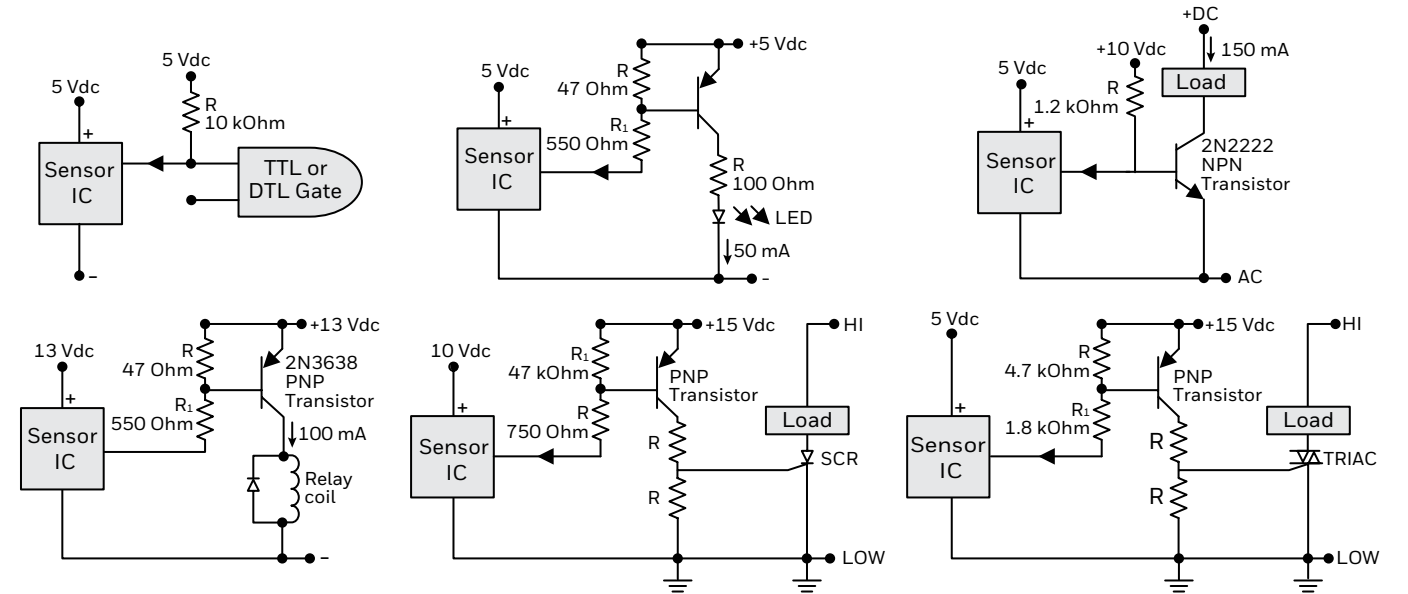

**Figure 8. Mounting and Dimensional Drawings (For reference only: mm/[in])**

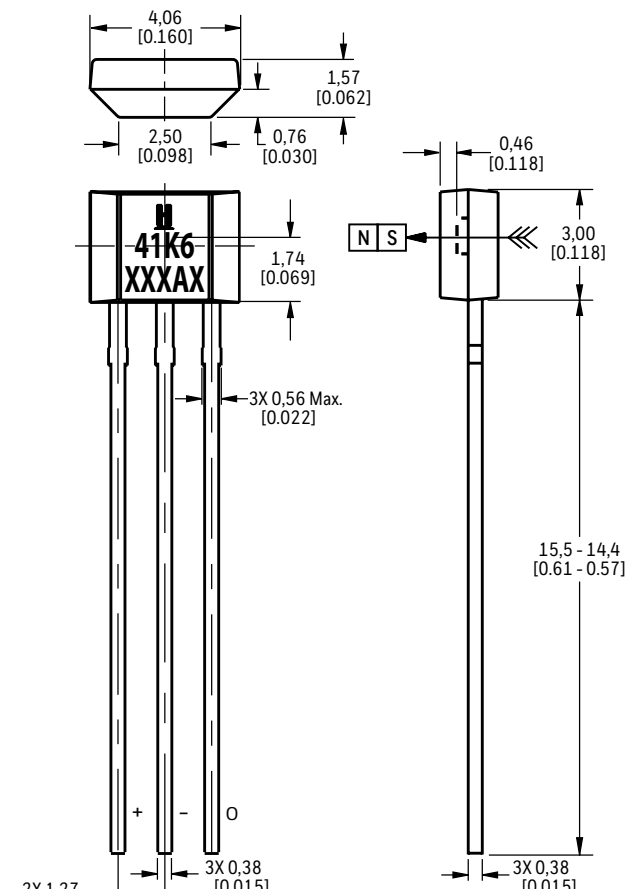

Note: Ensure the minimum hole size in the PCB is 0,68 mm [0,027] dia. based on the IPC 2222 Level B standard.

## **⚠️ WARNING**

### **PERSONAL INJURY**

DO NOT USE these products as safety or emergency stop devices or in any other application where failure of the product could result in personal injury.

**Failure to comply with these instructions could result in death or serious injury.**

### **Warranty/Remedy**

Honeywell warrants goods of its manufacture as being free of defective materials and faulty workmanship during the applicable warranty period. Honeywell's standard product warranty applies unless agreed to otherwise by Honeywell in writing; please refer to your order acknowledgement or consult your local sales office for specific warranty details. If warranted goods are returned to Honeywell during the period of coverage, Honeywell will repair or replace, at its option, without charge those items that Honeywell, in its sole discretion, finds defective.

**The foregoing is buyer's sole remedy and is in lieu of all other warranties, expressed or implied, including those of merchantability and fitness for a particular purpose. In no event shall Honeywell be liable for consequential, special, or indirect damages.**

While Honeywell may provide application assistance personally, through our literature and the Honeywell web site, it is buyer's sole responsibility to determine the suitability of the product in the application.

Specifications may change without notice. The information we supply is believed to be accurate and reliable as of this writing. However, Honeywell assumes no responsibility for its use.

### **For more information**

Honeywell Advanced Sensing Technologies services its customers through a worldwide network of sales offices and distributors.

For application assistance, current specifications, pricing or the nearest Authorized Distributor, visit [sps.honeywell.com/ast](https://sps.honeywell.com/ast) or call:

Asia Pacific +65 6355-2828

Europe +44 (0) 1698 481481

USA/Canada +1-800-537-6945

## **Honeywell Advanced Sensing Technologies**

830 East Arapaho Road  
Richardson, TX 75081  
[sps.honeywell.com/ast](https://sps.honeywell.com/ast)

32340615-B-EN | B | 05/21  
© 2021 Honeywell International Inc.

**Honeywell**