

FUNCTIONAL SAFETY CERTIFICATE

This is to certify that the

VPX Series Valve Position Indicator for Hazardous Locations

Manufactured by

Honeywell Sensing and Control

1668 Tianyin Road, Nanjing Science Park
Jiagning District, Nanjing,
Jiangsu,
211100,
China

315 E Stephenson Street,
Freeport,
Illinois,
61032
USA

Has been assessed by Sira Certification Service with reference to the
CASS methodologies and found to meet the requirements of

IEC 61508-2:2010 Routes 1_H & 1_S Systematic Capability (SC3)

As an element/subsystem suitable for use in safety related systems performing safety
functions up to and including

SIL 3 capable with HFT=0 (1oo1) *

When used in accordance with the scope and conditions of this certificate.

* This certificate does not waive the need for further functional safety verification to
establish the achieved Safety Integrity Level (SIL) of the safety related system

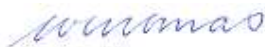

Certification Manager:

Wayne Thomas

Initial Certification : 15/11/2016
This certificate re-issued : 23/12/2019
Renewal date : 14/11/2021

This certificate may only be reproduced in its entirety, without any change.



Product description and scope of certification

The VPX Series Valve Position Indicator is designed specifically for use in most hazardous locations where explosive gases or dusts may be present. To comply with explosion proof requirements, the VPX has flame paths within the housing, which cool any explosion below the ignition temperature before it reach explosive gases or dusts in the surrounding atmosphere. Flame paths on the VPX are 1.) an extended shaft between the switch cavity and head and 2.) the cover-housing flange joint. The VPX Valve Position Indicator is often ideal for outdoor use or in adverse environments. The enclosure is sealed for protection against corrosion, water, dust and oil as defined in UL 50E to enclosure types 4, 4X, 6 and 13 as well as to IP66 and IP67 as defined in IEC 60529.

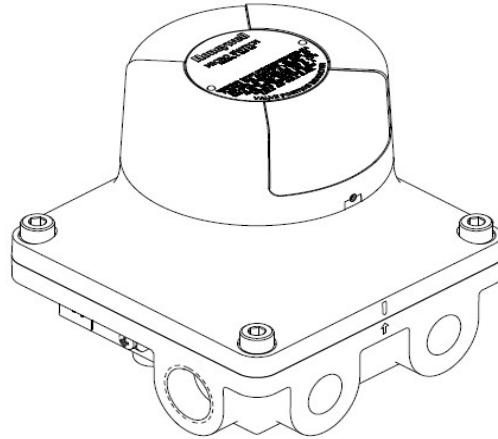

Figure 1. VPX Valve Position Indicator.

Honeywell offer two main variations of the VPX Valve Position Indicator, each of which are designed for different hazardous locations. The electromechanical snap action switches (EM switch) variant is designed to be used in an explosion proof application and uses four electro-mechanical switches in a redundant configuration, two monitoring the open position and two monitoring the closed position. The intrinsically safe proximity switches (IS Proxi) variant is designed to be used in an intrinsically safe application and has two proximity sensors, one monitoring the open position and one monitoring the closed position.

Element Safety Function

The safety function of the certified equipment is:

'To provide indication of a monitored valve position upon rotation of the shaft via switches or proximity sensors and a visual indicator.'

Certified Data in support of use in safety functions

The assessment has been carried out with reference to the *Conformity Assessment of Safety-related Systems* (CASS) methodology using the Route 1_H approach.

Based on the documents submitted by Honeywell Sensing and Control (China) Co., Ltd. the Failure Mode and Effect Analysis (FMEA) of the VPX Valve Position Indicator has verified the documents as evidence of Conformity to IEC 61508-2:2010 in respect of 'hardware safety integrity'. The components failure rates and modes for the VPX Valve Position Indicator have been extracted from or calculated using Quanterion Automated Databook and Item Toolkit.



Certificate No.: Sira FSP 16005/02
Form 7016 issue 5
Page 2 of 6



Sira Certification Service Part of CSA Group UK

Unit 6 Hawarden Industrial Park,
Hawarden, CH5 3US, United Kingdom.
Tel: +44 (0) 1244 670900
Email: ukinfo@csagroup.org
Web: www.csagroupuk.org

Table 1: Summary of assessment (1oo1) – VPX Valve Position Indicator (EM Switch)

1oo1 EQUATIONS

Parameter name	Symbol	Equation / source	Value/Result
Proof Test Interval	T1	IEC 61508-4 clause 3.8.5	8760 Hrs
Mean Time To Restoration	MTTR	IEC 61508-4 clause 3.6.21	8 Hrs
Mean Repair Time (Once revealed)	MRT	IEC 61508-4 clause 3.6.22	8 Hrs
Type A/B	Type	IEC 61508-2 clause 7.4.4.1.2 & 7.4.4.1.3	type A
Total failures:	λ	IEC 61508-4 clause 3.6.4	2.63E-07
Safe diagnosed failures:	λ_{SD}	IEC 61508-4 clause 3.6.8	0.00E+00
Safe undiagnosed failures:	λ_{SU}		2.39E-07
Dangerous diagnosed failures:	λ_{DD}	IEC 61508-4 clause 3.6.7	0.00E+00
Dangerous undiagnosed failures:	λ_{DU}		2.40E-08
Diagnostic coverage:	DC	$\lambda_{DD} / (\lambda_{DU} + \lambda_{DD})$	0%
Safe Failure Fraction:	SFF	$(\lambda_{SD} + \lambda_{SU} + \lambda_{DD}) / \lambda$	91%
PFD _{AVG}	PFD _{AVG}	$\lambda_{DU} (T / 2 + MRT) + (\lambda_{DD} MTTR)$	1.05E-04
SIL capability (Low demand mode)	SIL		SIL 3**

Table 2: Summary of assessment (1oo1) – VPX Valve Position Indicator (IS Proxi)

1oo1 EQUATIONS

Parameter name	Symbol	Equation / source	Value/Result
Proof Test Interval	T1	IEC 61508-4 clause 3.8.5	8760 Hrs
Mean Time To Restoration	MTTR	IEC 61508-4 clause 3.6.21	8 Hrs
Mean Repair Time (Once revealed)	MRT	IEC 61508-4 clause 3.6.22	8 Hrs
Type A/B	Type	IEC 61508-2 clause 7.4.4.1.2 & 7.4.4.1.3	type A
Total failures:	λ	IEC 61508-4 clause 3.6.4	4.74E-07
Safe diagnosed failures:	λ_{SD}	IEC 61508-4 clause 3.6.8	0.00E+00
Safe undiagnosed failures:	λ_{SU}		4.61E-07
Dangerous diagnosed failures:	λ_{DD}	IEC 61508-4 clause 3.6.7	0.00E+00
Dangerous undiagnosed failures:	λ_{DU}		1.33E-08
Diagnostic coverage:	DC	$\lambda_{DD} / (\lambda_{DU} + \lambda_{DD})$	0%
Safe Failure Fraction:	SFF	$(\lambda_{SD} + \lambda_{SU} + \lambda_{DD}) / \lambda$	97%
PFD _{AVG}	PFD _{AVG}	$\lambda_{DU} (T / 2 + MRT) + (\lambda_{DD} MTTR)$	5.85E-05
SIL capability (Low demand mode)	SIL		SIL 3**

** **Note 1:** The failure data:

- 1) The PFD_{AVG} figure shown is for illustration only assuming a proof test interval of 8760 hours and MTTR of 8 hours. Refer to IEC 61508-6 for guidance on PFD_{AVG} calculations from the failure data.
- 2) The verified failure rates used in the safe failure fraction and diagnostic coverage do not include (λ no part or no effect) failures in the calculation.

The failure data above is supported by the base information given in Table 3 below.



Table 3: Base information for the VPX Valve Position Indicator.

1	Product identification:	VPX Valve Position Indicator. - EM Switch - IS Proxi
2	Functional specification:	To return the valve to its closed position (spring extended) when de-energised.
3-5	Random hardware failure rates:	Refer to tables 1 & 2 of this certificate.
6	Environment limits:	Operating temperature ranges: -40°C to +85°C
7	Lifetime/replacement limits:	20 years.
8	Proof Test requirements:	Refer to the VPX installation instructions - 32312068
9	Maintenance requirements:	Refer to the VPX installation instructions - 32312068
10	Diagnostic coverage:	0% diagnostic coverage.
11	Diagnostic test interval:	Refer to the VPX installation instructions - 32312068
12	Repair constraints:	Refer to the VPX installation instructions - 32312068
13	Safe Failure Fraction:	See Tables 1 & 2 above.
14	Hardware fault tolerance (HFT):	See Tables 1 & 2 above.
15	Highest SIL (architecture/type A/B):	See Tables 1 & 2 above.
16	Systematic failure constraints:	The hardware safety integrity assessment was based on a proof test interval of 1 year. For further information, refer to the VPX installation instructions - 32312068
17	Evidence of similar conditions in previous use:	Not applicable for this product.
18	Evidence supporting the application under different conditions of use:	Not applicable for this product.
19	Evidence of period of operational use:	Not applicable for this product.
20	Statement of restrictions on functionality:	See systematic report R70080763B.
21	Systematic capability (SC1, SC2, SC3)	SC3 - See systematic report R70080763B.
22	Systematic fault avoidance measures:	Compliance with techniques and measures from IEC 61508-2 Annex B to SIL 3 - See systematic report R70080763B.
23	Systematic fault tolerance measures:	Compliance with techniques and measures from IEC 61508-2 Annex A to support the SFF achieved – see hardware safety integrity report R70080763A.
24	Validation records:	All documents that have been used in support of the hardware have been documented in section 5.26 of report R70080763A; this includes the FMEA document.

Management of functional safety

The assessment has demonstrated that the product is supported by an appropriate functional safety management system that meets the relevant requirements of IEC 61508-1:2010 clause 6, see report R70080763B.

Identification of certified equipment

The certified equipment and its safe use is defined in the documentation listed in Table 4 below.

Table 4:

Document no.	Rev	Date	Document description
VPX Series Chart 1	F	02/11/2016	Switch assembly for hazardous locations (E drawing).
VPX Series Chart 1	H	02/11/2016	Switch assembly for hazardous locations (I drawing).
32312068	D	N/A	Installation Instructions for the VPX series.
32304794	E	03/11/2016	Printed Wiring Assembly.
32304793	C	10/10/2016	Shaft Assembly.



Certificate No.: Sira FSP 16005/02
Form 7016 issue 5
Page 4 of 6

**Sira Certification Service
Part of CSA Group UK**

Unit 6 Hawarden Industrial Park,
Hawarden, CH5 3US, United Kingdom.
Tel: +44 (0) 1244 670900
Email: ukinfo@csagroup.org
Web: www.csagroupuk.org

Conditions of Certification

The validity of the certified base data is conditional on the manufacturer complying with the following conditions:

1. The manufacturer shall analyse failure data from returned products on an on-going basis. Sira Certification Service shall be informed in the event of any indication that the actual failure rates are worse than the certified failure rates. (A process to rate the validity of field data should be used. To this end, the manufacturer should co-operate with users to operate a formal field-experience feedback programme).
2. Sira shall be notified in advance (with an impact analysis report) before any modifications to the certified equipment or the functional safety information in the user documentation is carried out. Sira may need to perform a re-assessment if modifications are judged to affect the product's functional safety certified herein.
3. On-going lifecycle activities associated with this product (e.g., modifications, corrective actions, field failure analysis) shall be subject to surveillance by Sira in accordance with 'Regulations Applicable to the Holders of Sira Certificates'.

Conditions of Safe Use

The validity of the certified base data in any specific user application is conditional on the user complying with the following conditions:

1. The user shall comply with the requirements given in the manufacturer's user documentation in regard to all relevant functional safety aspects such as application of use, installation, operation, maintenance, proof tests, maximum ratings, environmental conditions, and repair.
2. Selection of this product for use in safety function and the installation, configuration, overall validation, maintenance and repair shall only be carried out by competent personnel, observing all the manufacturer's conditions and recommendations in the user documentation.
3. All information associated with any field failures of this product should be collected under a dependability management process (e.g., IEC 60300-3-2) and reported to the manufacturer.
4. The safety device is to have an independent power supply; it must not share the same power supply as non-safety devices that may cause a fault to the safety device.
5. A proof test interval of 1 year.

General Conditions and Notes

1. This certificate is based upon a functional safety assessment of the product described in Sira Test & Certification Assessment Reports R70080763A and R70080763B.
2. If the certified product or system is found not to comply, Sira Certification Service should be notified immediately at the address shown on this certificate.
3. The use of this Certificate and the Sira Certification Mark that can be applied to the product or used in publicity material are subject to the 'Regulations Applicable to the Holders of Sira Certificates' and 'Supplementary Regulations Specific to Functional Safety Certification'.
4. This document remains the property of Sira and shall be returned when requested by the issuer.
5. No part of the Functional safety related aspects stated in the instruction manual shall be changed without approval of the certification body.
6. This certificate will remain valid subject to completion of one surveillance audit within the five year certification cycle, and upon receipt of acceptable response to any findings raised during this period. This certificate can be withdrawn if the manufacturer no longer satisfies scheme requirements.



Certificate No.: Sira FSP 16005/02
Form 7016 issue 5
Page 5 of 6



Sira Certification Service Part of CSA Group UK

Unit 6 Hawarden Industrial Park,
Hawarden, CH5 3US, United Kingdom.
Tel: +44 (0) 1244 670900
Email: ukinfo@csagroup.org
Web: www.csagroupuk.org

Certificate History

Issue	Date	Report no.	Comment
00	15/11/2016	R70080763A R70080763B	The release of the prime certificate.
01	01/06/2017	R70017229	Certificate updated to include USA manufacturing site. This site was audited in March 2015, see referenced report.
02	23/12/2019	xxxxx	Address on page 1 amended to reference the Freeport facility – Galena Plant was removed.



Certificate No.: Sira FSP 16005/02
Form 7016 issue 5
Page 6 of 6



Sira Certification Service Part of CSA Group UK

Unit 6 Hawarden Industrial Park,
Hawarden, CH5 3US, United Kingdom.
Tel: +44 (0) 1244 670900
Email: ukinfo@csagroup.org
Web: www.csagroupuk.org