

DO NOT SCALE DRAWING	B-1104-D	REV.
ALL CHANGES TO DRAWING MUST BE DONE IN CAD	THIRD ANGLE PROJECTION	

"NOTICE TO PERSONS RECEIVING THIS DRAWING AND/OR TECHNICAL INFORMATION"  
 Lebow Products claims proprietary rights in the material disclosed herein. This drawing and/or technical information is issued in confidence for engineering information only and may not be reproduced or used to manufacture anything shown or referred to herein without direct written permission from Lebow Products to the user. This drawing and/or technical information is the property of Lebow Products and is loaned for mutual assistance, to be returned when its purpose has been served.

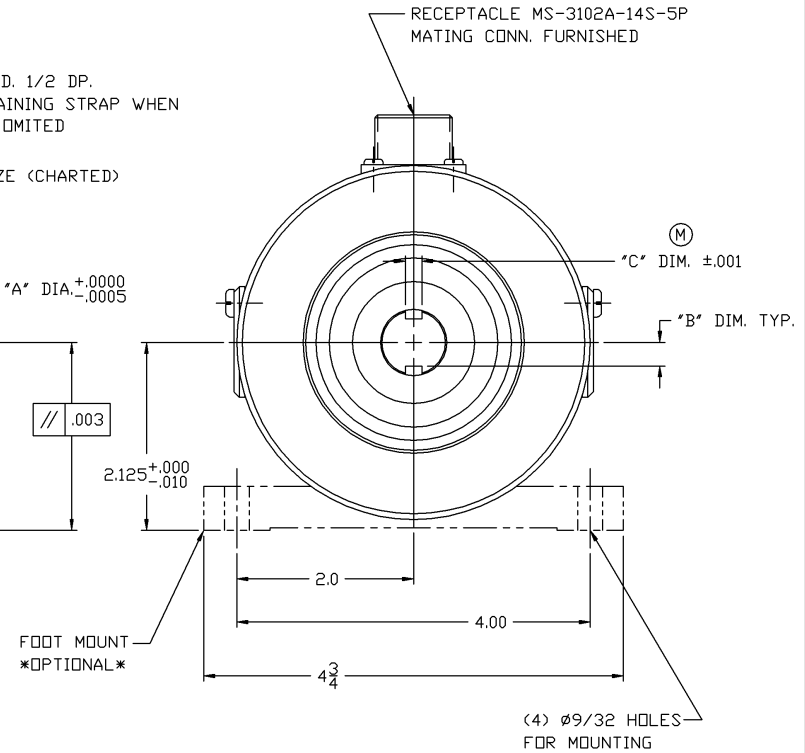
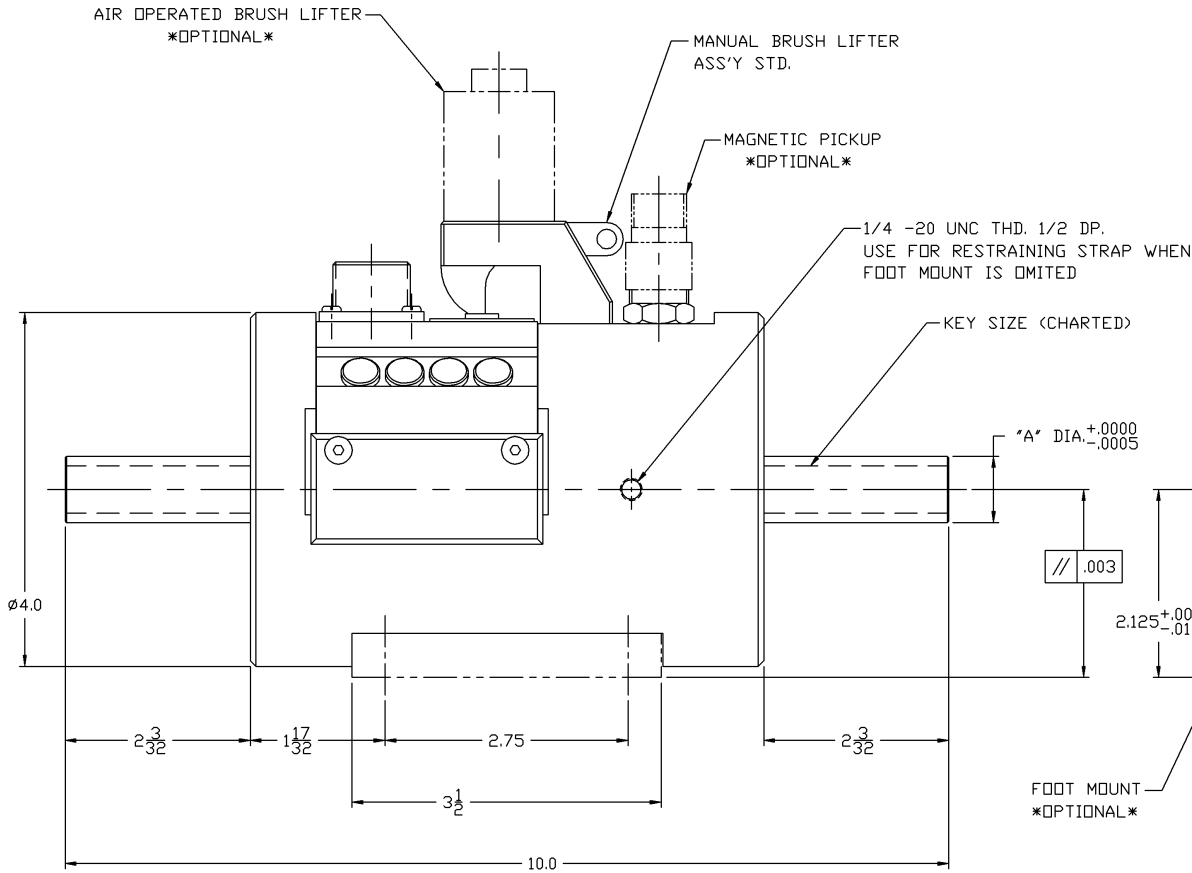

SPEED: 9000 R.P.M. MAX.

(M)

MODEL #	CAP. IN. LBS.	"A" DIA.	"B" DIM.	"C" DIM.	KEY SIZE
1104-400	400	.750	.264/.269	.1875	3/16 X 1 3/4
1104-2K	2000	1.000	.354/.359	.250	1/4 X 1 3/4
1104-1K	1000	1.000	.354/.359	.250	1/4 X 1 3/4
1104-500	500	1.000	.354/.359	.250	1/4 X 1 3/4
1104-200	200	.750	.264/.269	.1875	3/16 X 1 3/4
1104-100	100	.750	.264/.269	.1875	3/16 X 1 3/4
1104-50	50	.750	.264/.269	.1875	3/16 X 1 3/4

DET. NO.	PART NO.	DESCRIPTION	REV.
		<b>Lebow Products</b> Lebow Products Troy, Michigan	
UNLESS OTHERWISE SPECIFIED LINEAR DIMENSIONS ARE IN INCHES ANGULAR DIMENSIONS ARE IN DEGREES DIMENSION LIMITS HELD AFTER PLATING REMOVE ALL BURRS & SHARP EDGES SURFACE FINISH 125 <input checked="" type="checkbox"/>			
<b>TOLERANCES</b>			
DRILLED HOLES $^{+.000}_{-.007}$	TWO PLACE DECIMALS $\pm .001$	THREE PLACE DECIMALS $\pm .0005$	ANGLES $\pm 0' 30''$
SCALE: NONE	REF. DIM: C-12812	FRACTIONAL DIMENSIONS $\pm 1/64$	MATL: -
DATE: M/J	APPR'D: M/J	CHG'D: M/J	ECN NO. -
TITLE: O. D.			DRAWING NO. B-1104-D