

VG481V1

Back Biased Hall-effect Speed Sensor Integrated Circuit (IC)

DESCRIPTION

The VG481V1 contains a dual peak detecting circuit that is coupled with a Hall-effect element to detect the speed of a ferrous gear tooth target wheel. A biasing magnet provides a changing magnetic field as the target wheel moves past the sensor IC. The sensor IC functions in reference to peak and slot magnetic levels. The sensor IC output is in either a high state or a low state, which corresponds to the target tooth/slot features. The VG481V1 IC consists of a voltage regulator, clock/oscillator, Hall-element, amplifier, internal peak/valley track and hold circuits, comparator, and open collector output stage. The sensor IC is protected from abnormal operation at low voltage by a power-on rest circuit. The output circuitry contains short circuit protection. The voltage regulator contains reverse connection protection. The slicing level is derived from the stored peak and valley values. A start-up algorithm holds the output state until the slicing level has reached a stable position. The VG481V1 is zero speed capable after initial startup as long as power is applied. The VG481V1 IC is offered in flat TO-92-style package with straight leads in bulk packaging which allows for a compact PC board layout.

DIFFERENTIATION

Provides lesser operate point variation.

VALUE TO CUSTOMERS

- Uses a dual peak detecting circuit derived from the stored peak and valley values. This provides zero speed capability and more accurately tracks targets that exhibit run-out and other variations.
- AEC-Q100 qualified and often suitable for automotive applications.
- Provides higher accuracy.

POTENTIAL APPLICATIONS

- Transportation: Transmission speed sensing
- General speed sensing

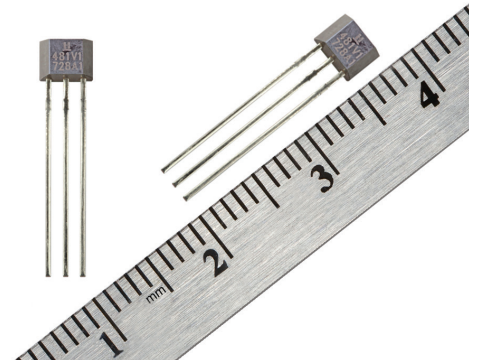

FEATURES

- Back-biased speed sensor IC
- Zero-speed capable
- Low cost and easy to use
- 4 V to 24 V supply voltage range
- -40°C to 150°C operating temperature range
- Open collector output rated for 20 mA
- Output short circuit protection
- Reverse voltage protected
- Qualified to AEC-Q100 (Grade 0)



PORTFOLIO

The Honeywell VG481V1 Speed Sensor IC joins the following related products: VM721V1, VM721D1, VF401, VF526DT. To view the entire product portfolio, [click here](#).

BACK-BIASED HALL-EFFECT SPEED SENSOR INTEGRATED CIRCUIT ICs

VG481V1

TABLE 1. ELECTRICAL SPECIFICATIONS (AT 4.0 V ≤ V_S ≤ 24 V, -40°C ≤ T_A ≤ 150°C, UNLESS OTHERWISE SPECIFIED)

CHARACTERISTIC	CONDITION	MIN.	TYP.	MAX.	UNIT
Supply voltage	Pin 2 referenced to Pin 1	4	14	24	V
Reverse supply voltage	current < 10 mA	—	—	-26	V
Supply current	V _{supply} = 24 V, with “ON” state	—	—	10	mA
Startup time	V _{supply} = 4 V	—	—	10	ms
Output short circuit	short load	—	10	—	μs
Output leakage current	V _{supply} = 24 V, with “OFF” state	—	—	10	μA
Output current (sinking)	continuous operation (recommended)	—	—	5	mA
Output saturation voltage	sinking 20 mA	—	—	360	mV
Switching frequency: rise time	V _{CC} = 12 V, R _L =2 kOhm; C _L = 20 pF	—	—	10	μs
fall time	V _{CC} = 12 V, R _L =2 kOhm; C _L = 20 pF	—	—	1	μs
Power up ramp time ¹	0 V to 4 V, power up in high state	—	—	1	ms

¹If the power up ramp time from 0 V to 4 V is greater than 1 ms, proper IC functionality cannot be guaranteed.

TABLE 2. MAGNETIC SPECIFICATIONS

CHARACTERISTIC	CONDITION	MIN.	TYP.	MAX.	UNIT
Back bias range	South pole facing back of package	500	—	4000	Gauss
Peak magnetic field	for linear operation	—	—	4500	Gauss
Switching differential	25°C	—	5	—	Gauss
Minimum signal lockout	peak to valley difference	—	38.5	—	Gauss
Magnetic signal	continuous operation (recommended)	75	—	—	Gauss
Output signal frequency	—	0	27.5	10000	Hz
Die placement tolerance	X and Y	-0.07	—	0.07	mm

TABLE 3. ENVIRONMENTAL SPECIFICATIONS

CHARACTERISTIC	CONDITION	MIN.	TYP.	MAX.	UNIT
ESD (HBM)	JEDEC JS-001	8	—	—	kV

TABLE 4. ABSOLUTE MAXIMUM RATINGS

CHARACTERISTIC	CONDITION	MIN.	TYP.	MAX.	UNIT
Operating temperature	ambient	-40	—	150	°C
Storage temperature	ambient, unbiased	-55	—	150	°C
Soldering temperature	applied for <10 s	—	—	265	°C
Output current (sinking)	open collector	—	—	20	mA
Forward supply voltage	dc voltage for 1 hour	—	—	26	V
Reverse supply voltage	dc voltage for 1 hour	-26	—	—	V

NOTICE

Absolute maximum ratings are the extreme limits the device will momentarily withstand without damage to the device. Electrical and mechanical characteristics are not guaranteed if the rated voltage and/or currents are exceeded, nor will the device necessarily operate at absolute maximum ratings.

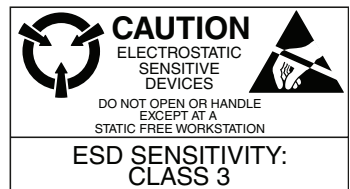

BACK-BIASED HALL-EFFECT SPEED SENSOR INTEGRATED CIRCUIT ICS VG481V1

TYPICAL OPERATION

Figure 1 shows the circuit's high level block diagram. During normal operation, peak maximum and valley minimum values, proportional to the magnetic signal, are tracked and held. The average of these two values is used to produce a slicing level that is compared to the input signal to produce the output transitions.

Upon transition from output low to high state, the valley minimum value is preloaded in the positive direction, an amount equal to the difference of the previous peak and valley divided by four. Likewise, upon transition from output high to low state, the peak maximum is preloaded in the negative direction in an amount equal to the difference of the previous peak and valley divided by four (see Figure 2).

The preload values are calculated from the peak and valley counter register values. This preload function allows the sensor to track targets with run-out and other variations.

FIGURE 1. HIGH LEVEL CIRCUIT BLOCK DIAGRAM

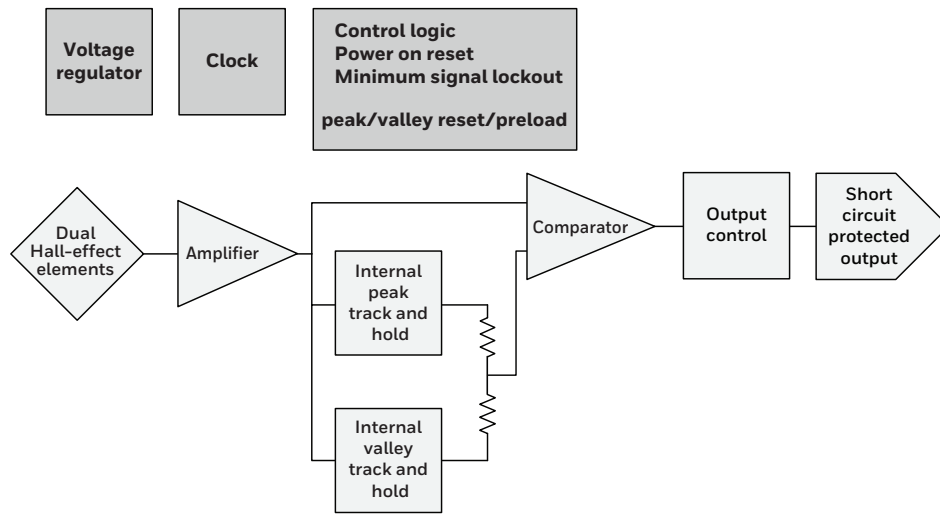
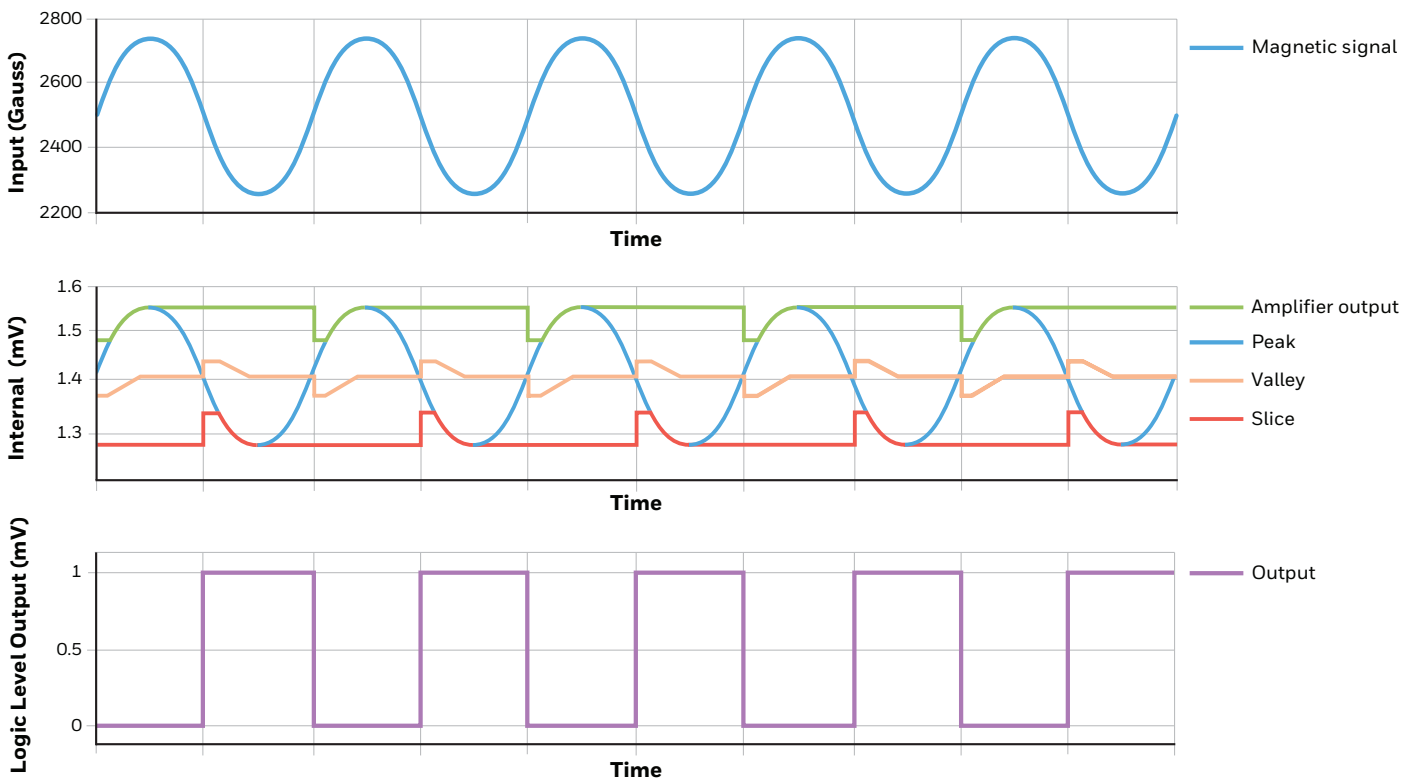

FIGURE 2. HIGH LEVEL OPERATION



BACK-BIASED HALL-EFFECT SPEED SENSOR INTEGRATED CIRCUIT ICS VG481V1

INTERNAL TRACK AND HOLD OPERATION (See Figures 3, 4)

The input voltage is constantly compared to the voltage held at the output of the peak hold circuit.

Whenever the input is higher than the peak hold value, the comparator triggers the counter to increment. This continues until the input value no longer exceeds the peak hold value.

The internal valley track and hold circuit works identically, except in the opposite direction. The peak hold and valley hold outputs are averaged to produce the slicing level.

FIGURE 3. INTERNAL PEAK TRACK AND HOLD BLOCK DIAGRAM

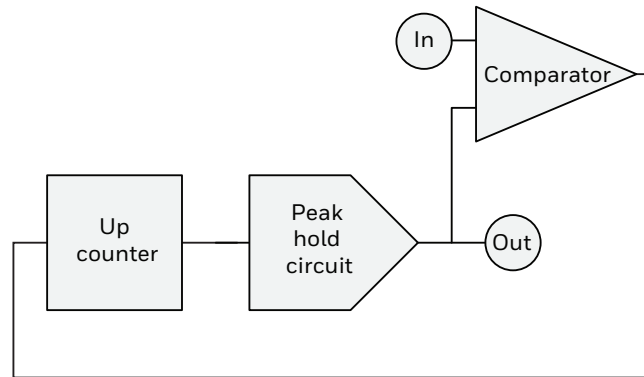
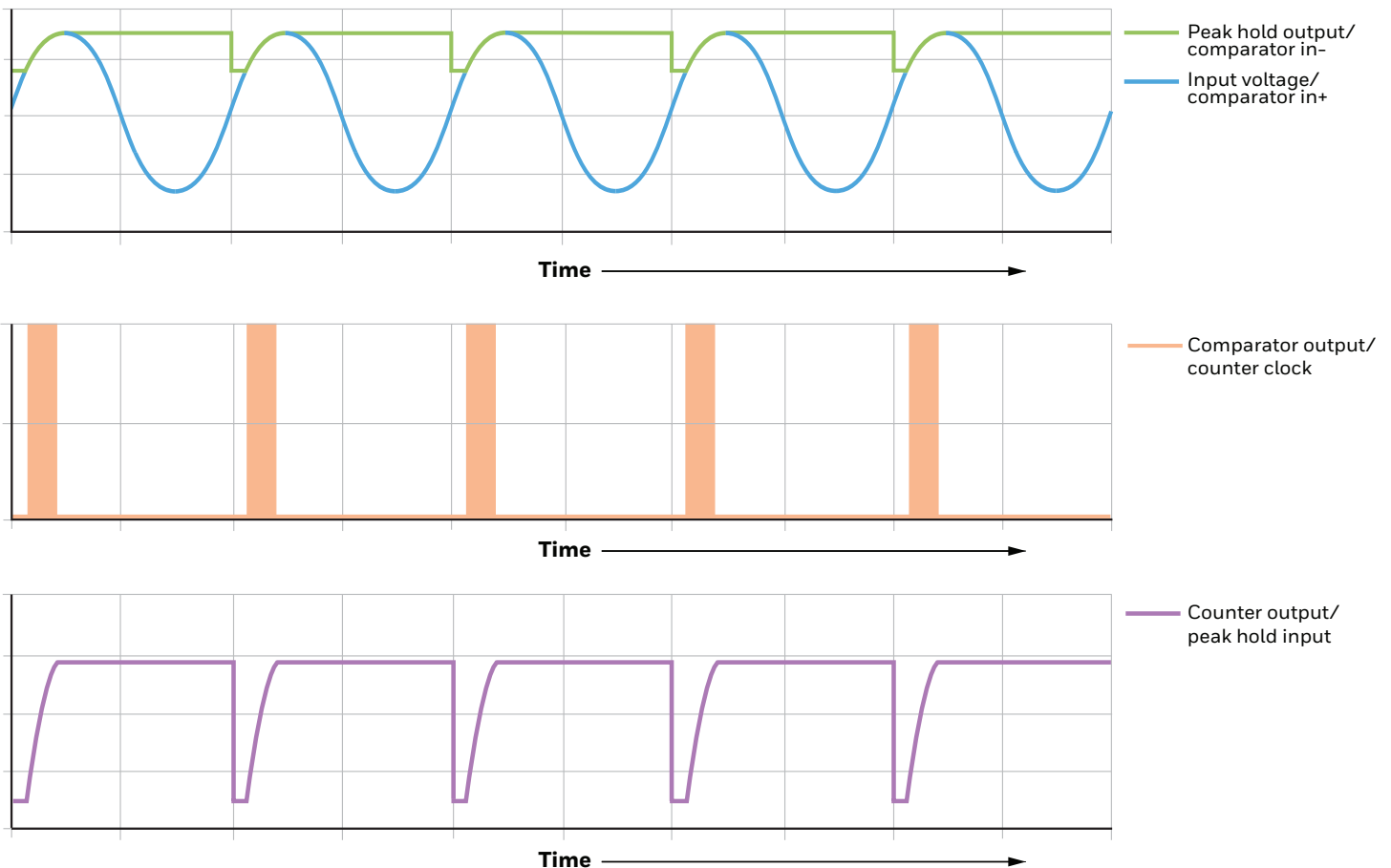

FIGURE 4. INTERNAL PEAK SAMPLE AND HOLD OPERATION



BACK-BIASED HALL-EFFECT SPEED SENSOR INTEGRATED CIRCUIT ICS VG481V1

POWER ON RESET

At power up, and any time the supply voltage drops below a level that allows reliable operation, the sensor IC ceases operation and will not provide an output until the supply voltage rises to a proper level. The output will be high until the power on reset releases, and it will remain high until the first valid high-to-low transition.

FIGURE 5. MINIMUM CIRCUIT FOR OPERATION

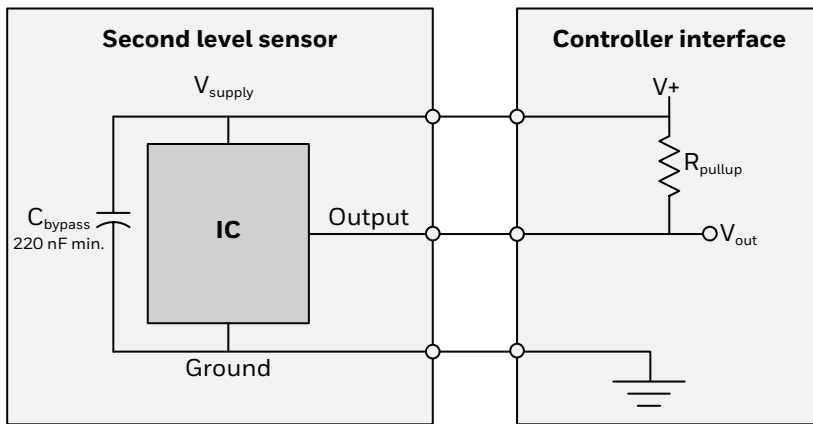
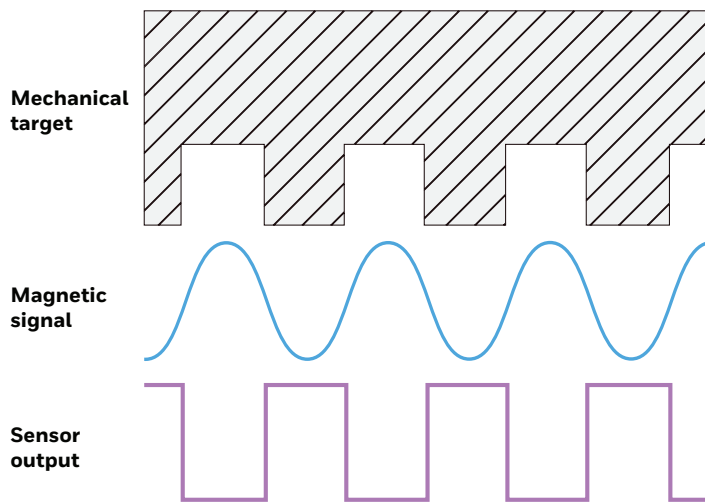

FIGURE 6. TYPICAL OUTPUT SIGNAL RELATIVE TO MECHANICAL TARGET



MINIMUM SIGNAL LOCKOUT

Sensor IC output is enabled when the peak-to-valley difference is greater than 38.5 Gauss typical. When the peak-to-valley difference degrades to less than 27.5 Gauss typical, the sensor IC output is disabled.

STARTUP SEQUENCE

Sensor IC startup consists of three stages:

1. **Power on reset circuit release:** This occurs once sufficient stable operating voltage is applied.
2. **Internal peak and valley track and hold circuits begin to fully track the input signal:** This is typically less than 1 ms.
3. **Minimum signal lockout release:** This occurs when the peak-to-valley difference is greater than 38.5 Gauss.

After the three startup stages, the sensor IC output will switch normally.

FIGURE 7. PACKAGE DIMENSIONS (FOR REFERENCE ONLY: MM/[IN])

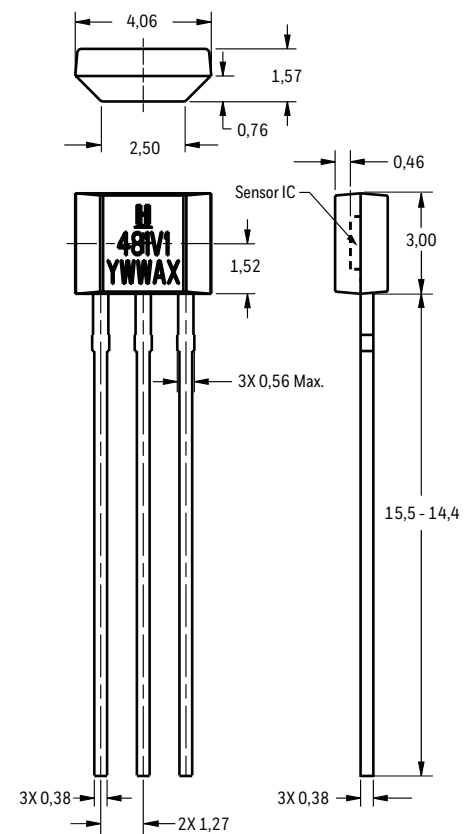

Note: Ensure the minimum hole size in the PCB is 0.68 mm [0.027] dia. based on the IPC 2222 Level B standard.

BACK-BIASED HALL-EFFECT SPEED SENSOR INTEGRATED CIRCUIT ICS VG481V1

SENSOR IC MOUNTING

The recommended sensor IC mounting position is in front of a gear wheel (see Figure 8). The south pole of the back bias magnet must face the back of the sensor IC package. The sensing distance is measured between the sensor IC front and the tip of the gear tooth. The sensor IC senses ferrous targets. The sensor IC contains a single Hall element and a symmetrical magnet such that the sensor IC can be rotated on its axis with no performance degradation. The input voltage is constantly compared to the voltage held at the output of the peak hold circuit. Whenever the input is higher than the peak hold value, the comparator triggers the counter to increment. This continues until the input value no longer exceeds the peak hold value.

FIGURE 8. SENSOR IC MOUNTING

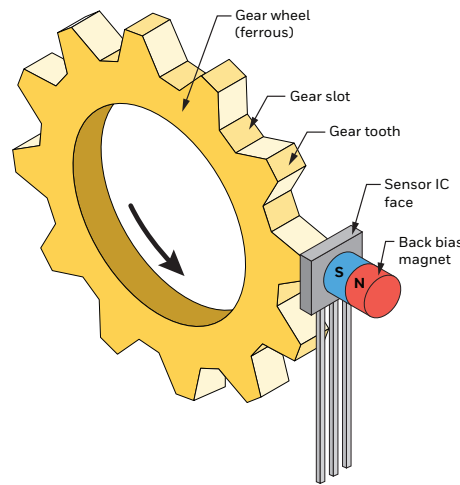

NOTICE

Observe the following precautions when using magnetometers in general:

- The presence of ferrous materials, such as nickel iron, steel and cobalt near the sensor will create disturbances in the earth's magnetic field that will distort x, y, z axis measurements. Non-ferrous materials such as copper brass, gold, aluminum, some stainless steel, silver, tin silicon, and any nonmetallic material will not distort the field measurements.
- The presence of the earth's magnetic field must be taken into account when measuring the x, y, z fields and it varies considerably in different parts of the world. Differences in the earth's magnetic field are quite dramatic between North America, South America, and the equator.
- Typical targets are the 120 mm to 300 mm in diameter. The tooth shapes vary (square, triangular, windows). The teeth are of similar size, equally spaced, and with no signature features. The sensing distance depends on the tooth/slot spacing and frequency due to eddy current effects.

TABLE 5. ORDER GUIDE

CATALOG LISTING	DESCRIPTION
VG481V1	Back-biased Hall-effect speed sensor, flat TO-92-style package, straight standard leads, bulk packaging (1000 units/bag)



ADDITIONAL MATERIALS

The following associated literature is available at sensing.honeywell.com:

- Product range guide
- Magnetic Sensor IC Line Card
- Magnetic Sensor IC Selection Chart
- Product Installation instructions

WARRANTY/REMEDY

Honeywell warrants goods of its manufacture as being free of defective materials and faulty workmanship during the applicable warranty period. Honeywell's standard product warranty applies unless agreed to otherwise by Honeywell in writing; please refer to your order acknowledgment or consult your local sales office for specific warranty details. If warranted goods are returned to Honeywell during the period of coverage, Honeywell will repair or replace, at its option, without charge those items that Honeywell, in its sole discretion, finds defective.

The foregoing is buyer's sole remedy and is in lieu of all other warranties, expressed or implied, including those of merchantability and fitness for a particular purpose. In no event shall Honeywell be liable for consequential, special, or indirect damages.

While Honeywell may provide application assistance personally, through our literature and the Honeywell web site, it is buyer's sole responsibility to determine the suitability of the product in the application.

Specifications may change without notice. The information we supply is believed to be accurate and reliable as of this writing. However, Honeywell assumes no responsibility for its use.

FOR MORE INFORMATION

Honeywell Sensing and Internet of Things services its customers through a worldwide network of sales offices and distributors. For application assistance, current specifications, pricing or the nearest Authorized Distributor, visit sensing.honeywell.com or call:

Asia Pacific +65 6355-2828
Europe +44 1698 481481
USA/Canada +1-800-537-6945

Honeywell Sensing and Internet of Things

9680 Old Bailes Road
Fort Mill, SC 29707
www.honeywell.com

005992-3-EN | 3 | 02/20
© 2020 Honeywell International Inc. All rights reserved.

WARNING PERSONAL INJURY

DO NOT USE these products as safety or emergency stop devices or in any other application where failure of the product could result in personal injury.

Failure to comply with these instructions could result in death or serious injury.

WARNING MISUSE OF DOCUMENTATION

- The information presented in this product sheet is for reference only. Do not use this document as a product installation guide.
- Complete installation, operation, and maintenance information is provided in the instructions supplied with each product.

Failure to comply with these instructions could result in death or serious injury.

Honeywell