

HONEYWELL PART NUMBER
-

REV	DOCUMENT	CHANGED BY	CHECK
A	0079416	MH 14MAR11	VSY

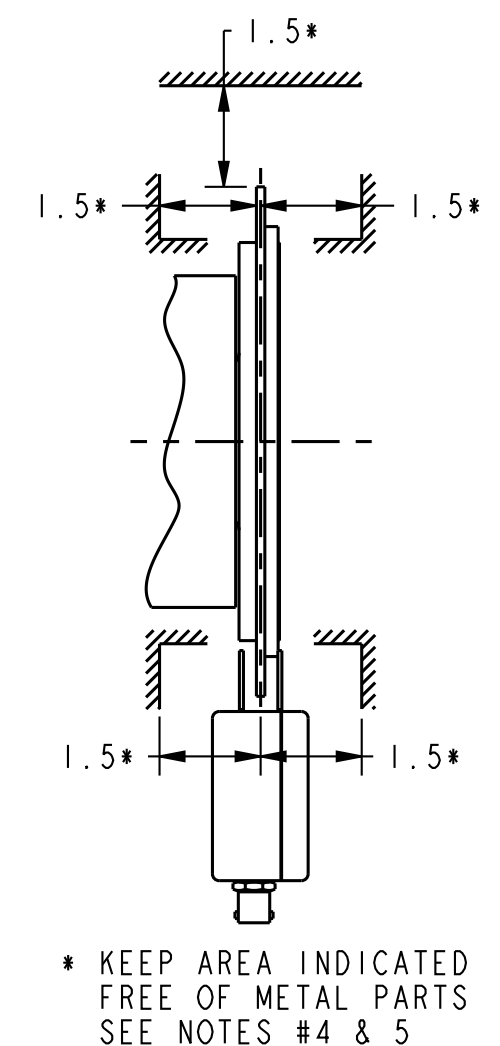
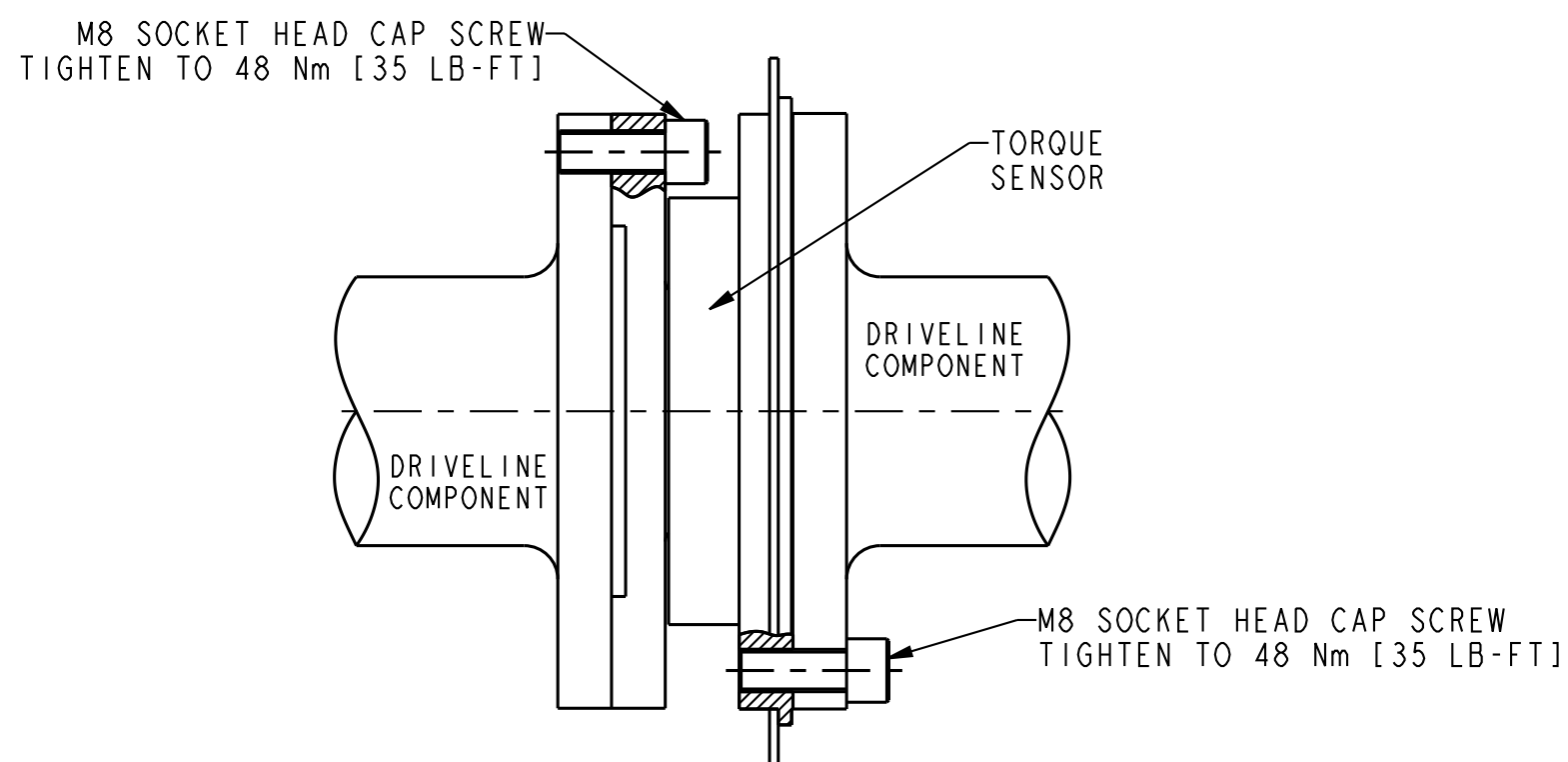
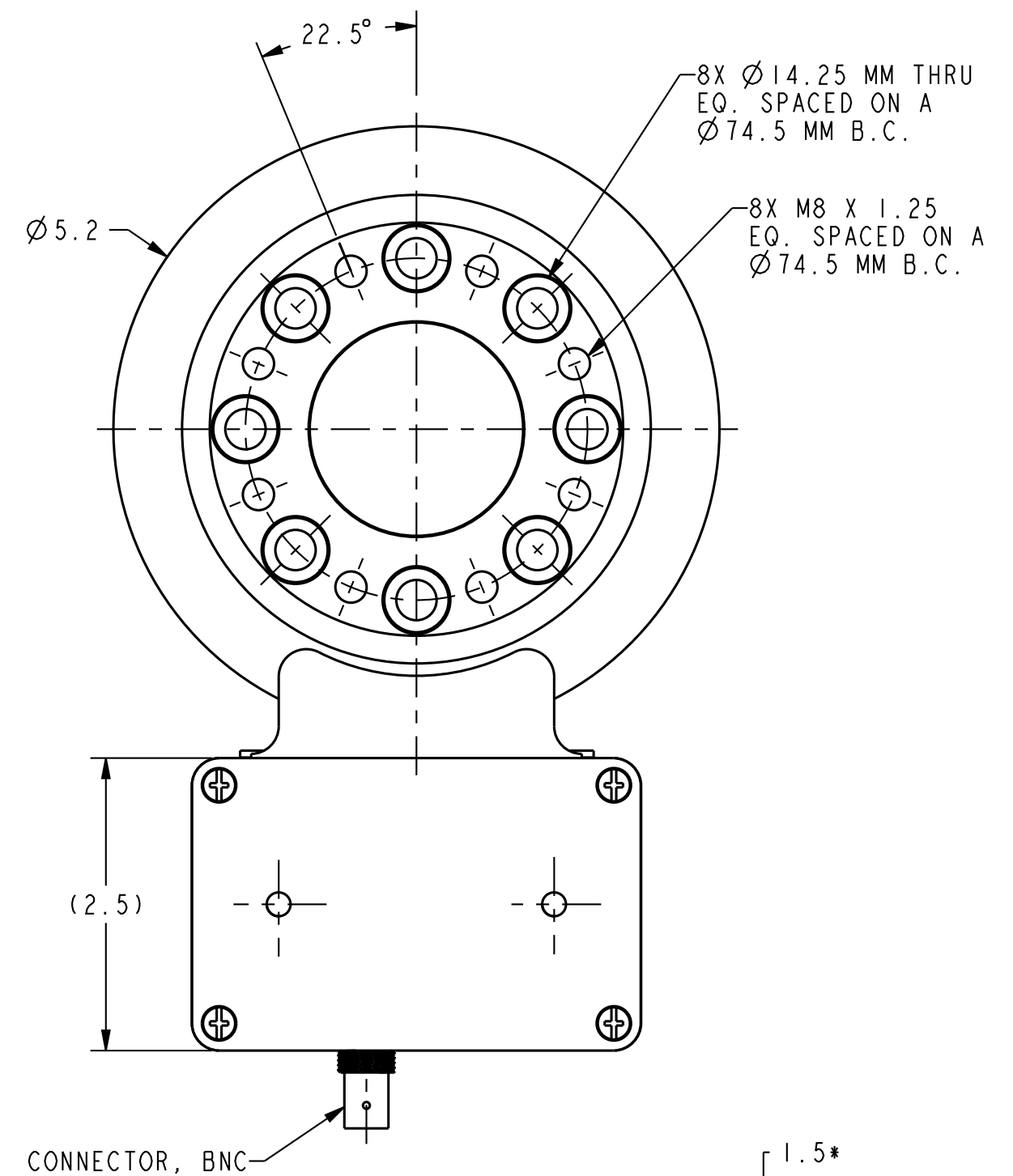
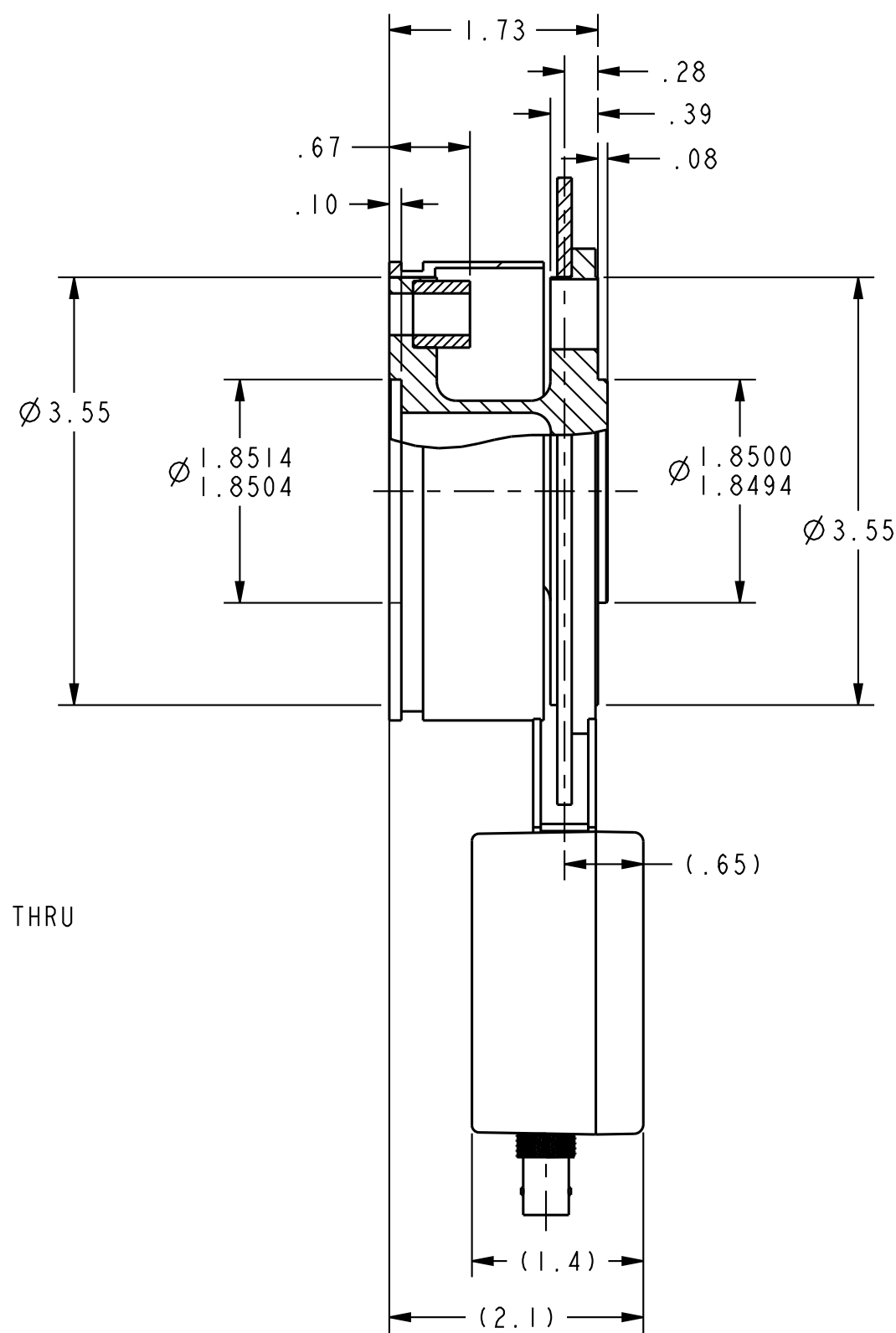
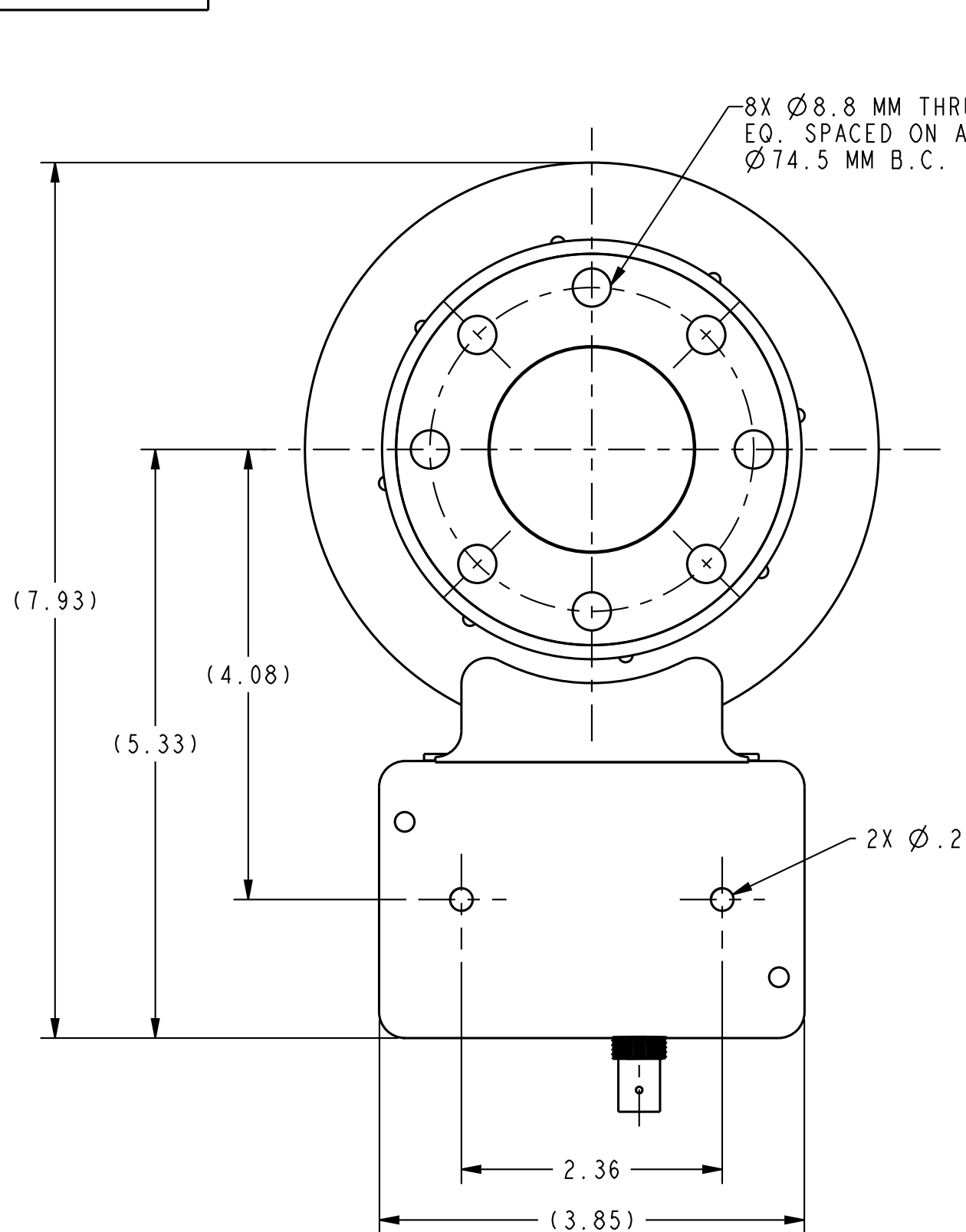

- NOTES
- 1 - SENSOR IS NOT DYNAMICALLY BALANCED.
  - 2 - PILOT DIAMETERS IN ACCORDANCE WITH ANSI B4.1 (ANSI STANDARD FOR LIMITS & FITS)
  - 3 - USE THREAD LOCKING COMPOUND AN ALL THREADS.

DESIGN UNITS: INCH TOLERANCES UNLESS NOTED:	DRAWN DN 02DEC10	<b>Honeywell</b>	
NO PLACES x ± -	CHECK VSY 02DEC10		
ONE PLACE .x ± .2	THIS DRAWING COVERS A PROPRIETARY ITEM AND IS THE PROPERTY OF HONEYWELL. THIS DRAWING IS NOT TO BE COPIED OR USED WITHOUT THE PERMISSION OF HONEYWELL.		TITLE
TWO PLACE .xx ± .02			OD DRAWING, MODEL 92512
THREE PLACE .xxx ± .010	INTERPRET PER ASME Y14.5M-1994 OTHER HONEYWELL ENGINEERING STANDARDS MAY APPLY	SIZE TYPE CAGE CODE DRAWING NAME	REV
ANGLES x ± 0.5°	Pro/ENGINEER 3D	C I - 000-LW92512	A
THIRD ANGLE PROJECTION	SCALE 3:4	SHEET 1 OF 1	